

FICHE D'HOMOLOGATION HOMOLOGATION FORM

3/SA/18



COMMISSION INTERNATIONALE DE KARTING - FIA



SILENCIEUX D'ASPIRATION / INTAKE SILENCER

Constructeur	<i>Manufacturer</i>	Giacoletto Pierluigi
Marque	<i>Make</i>	KG
Modèle	<i>Model</i>	APE1
Catégories	<i>Categories</i>	KZ & KF G1
Durée de l'homologation	<i>Validity of the homologation</i>	9 ans / 9 years
Nombre de pages	<i>Number of pages</i>	4

La présente Fiche d'Homologation reproduit descriptions, illustrations et dimensions du silencieux d'aspiration au moment de l'homologation CIK-FIA et du test d'homologation. Le Constructeur a la possibilité de les modifier seulement dans les limites fixées par le règlement CIK-FIA en vigueur.

This Homologation Form reproduces descriptions, illustrations and dimensions of the intake silencer at the moment of the CIK-FIA homologation and of the homologation test. The Manufacturer may modify them, but only within the limits fixed by the CIK-FIA regulations in force.



PHOTO DE L'AVANT
PHOTO OF THE FRONT



PHOTO DE CÔTÉ
PHOTO OF THE SIDE

Signature et tampon de l'ASN
Signature and stamp of the ASN

Signature et tampon de la CIK-FIA
Signature and stamp of the CIK-FIA



Gravina



[Signature]

A	DESCRIPTIONS TECHNIQUES	A	TECHNICAL DESCRIPTIONS
	Volume en cm ³		Volume in cc
	Matériau		3960cm ³ +/-2%
	Nombre d'ouvertures d'admission d'air		MATERIAL
	Longueur des conduits d'admission		POLIPROPILENE
	Diamètre des conduits d'admission		2
	Surface de l'élément filtrant intérieur		176mm +/-2% (≥98mm)
	Epaisseur de l'élément filtrant		30mm max.
			218cm ² +/-2% (≥200cm ²)
			16mm -10%

A1	Dessin technique [dimensions d'encombrement – diamètre du (des) tube(s) d'admission – diamètre de la fixation au carburateur]	A1	Technical drawing [main external dimensions – diameter of the inlet tube(s) – diameter of the fixation to the carburettor]
----	--	----	---

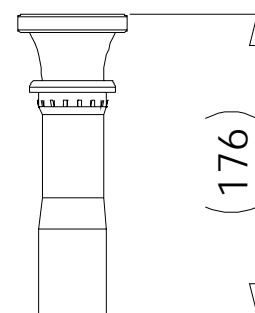
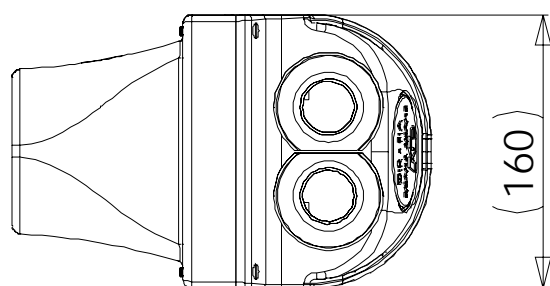

MAX 30 mm

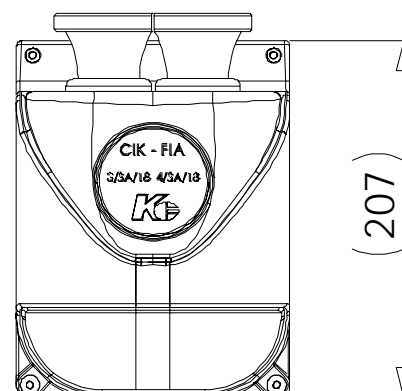
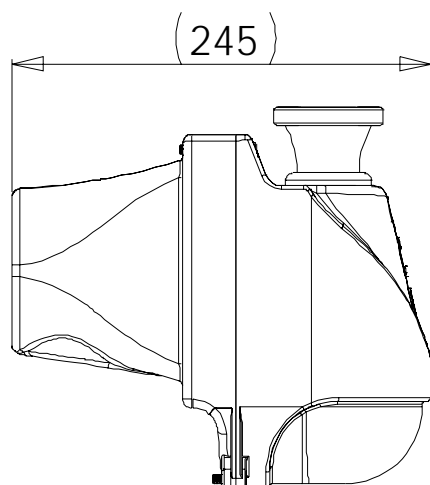

A2	Dessin technique explosé	A2	<i>Exploded technical drawing</i>
----	--------------------------	----	-----------------------------------

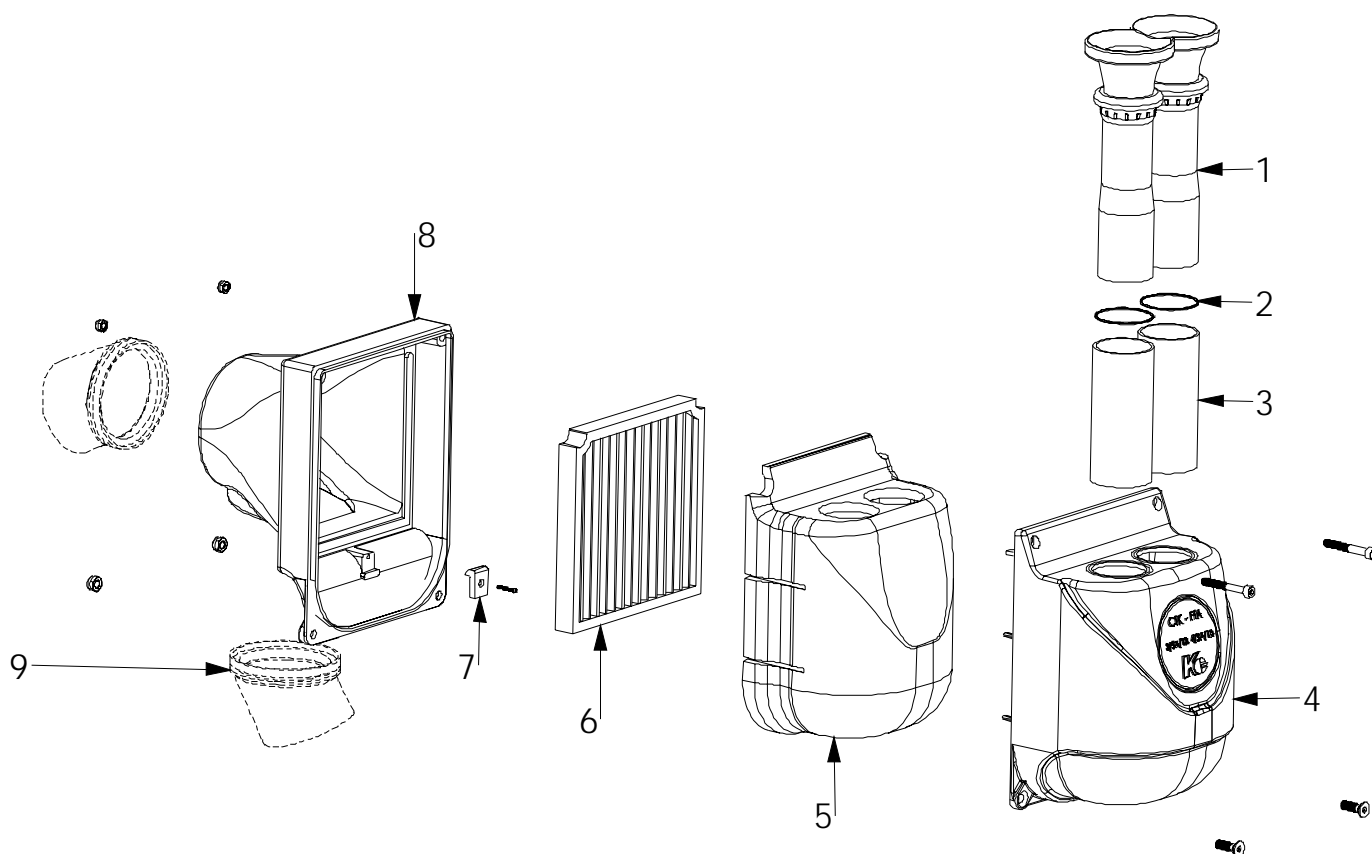

Le dessin technique explosé doit montrer : Eléments du silencieux, éléments acoustiques absorbants, éléments filtrants, tubes d'aspiration et manchon de fixation au carburateur.

The exploded technical drawing must show the following: parts of the silencer, noise-absorbing parts, filtering parts, suction tubes and carburettor clamping sleeve.

N°	DÉSIGNATION	DESIGNATION	Référence catalogue <i>Catalogue reference number</i>
1	Tube démontable de boîte à air Ø 30mm	Intake tube Ø 30 mm	RC.141.30
2	Oring	Oring intake tube	RC.142
3	Revetement insonorisation	Soundproofing coating	RC.145.8
4	Coque supérieure	Front case APE silver	RC.137.AG
5	Silencieux interne	Absorbing element case APE	RC.146.8
6	Filtre	Panel filter APE	RC.144
7	Serre filtre	Internal filter clamp bracket	RC.148
8	Coque inférieure	Rear case APE silver (side duct)	RC.139.AG
9	Collier serflex pour fixation de boîte à air	Air box rubber connector	RC.143